



One step ahead on the future

Mech Series



Mech Series

Automationware

Series: Value – Line – Force – Plus & Extreme

Mech Value Series

Small-sized electric cylinders, for high performance in terms of speed and resistance, based on a sphere recirculation screw technology, available in a normal or parallel version to optimize spaces.

They are equipped with innovative high-speed Stepper motors with encoder or in the Sensorless version, a new technology making use of motor control parameters to detect correct position without installing an encoder, thus reducing costs and sizes.

The cylinder profiles are also designed to include the **AwareVu** technology for detecting vibrations in the installation area. (Ind. 4.0)

Available sizes **16 - 25 - 32**, with direct or delayed Stepper motor for easier adjustability.



Features/Model	UM	Mech Value 16	Mech Value 25	Mech Value 32
Flange Size	mm	30 mm	32 mm	42 mm
Diameter / Step Screw	mm	8/-2-8	10/-3-10	12/-5-10
Accuracy	mm	±0.02	±0.02	±0.02
Maximum axial force	N	325-50	833-105	1700-250
Maximum Motor Speed (Stepper)	rpm	3000	3000	3000
Maximum screw speed	rpm	3000	3000	3000
Maximum axial speed	mm/s	100-400	150-500	250-500
Useful Ride* (Non standard available under request)	mm	50-300	50-400	50-500

Mech Series

Automationware

Series: Value – Line – Force – Plus & Extreme

Serie Mech Line

Highly reliable and widespread cylinders, a consolidated product with an excellent price-performance ratio.

They are available on four sizes, **25 - 32 - 50 - 63**, using sphere recirculation screw movement, and are equipped with an anti-rotation device.

They are ISO 15552 compatible.

They can be powered using Stepper or Brushless motors, also with closed-ring control.

Motor power may be direct or delayed.



Features/Model Line	UM	Mech Line 25	Mech Line 32	Mech Line 50	Mech Line 63
Flange Size	mm	32 mm	47 mm	65 mm	75 mm
Diameter / Step Screw	mm	10/3-10	12/5-10	16/5-10-16	20/5-10-20
Dynamic load	kN	2,8-2,5	5,14-3,90	10,49-11,81-8,33	14,6-11,0-13,4
Axial force 2000km	kN	0,32-0,43	0,69-0,67	1,42-2,02-1,67	1,98-1,88-2,89
Maximum screw speed	rpm	4500	4500	4500	4500
Maximum axial speed	mm/s	750	750	1200	1500
Useful Ride* (Non standard available under request)	mm	50-300	50-400	50-500	50-500

Mech Series

Automationware

Series: Value – Line – Force – Plus & Extreme

Mech Force Series

The **Mech Force series** is suitable for the most extreme workloads or in situations where heavy-duty operation is required with a high dynamic load over time.

The profile has a reinforced structure and the driving technology consists in customized sphere recirculation screws, to achieve high dynamic loads offering optimal speed performances thanks to the various step options.

They are ISO 15552 compatible, can be powered by Brushless or Stepper motors, which can also be coupled to gearboxes in order to take up less space and provide a comprehensive solution.

They can include the **AwareVu** device which gives continuous feedback on operation under standard conditions, warning in advance about any maintenance needs.

The **Mech Force 150** version has a Steel structure.

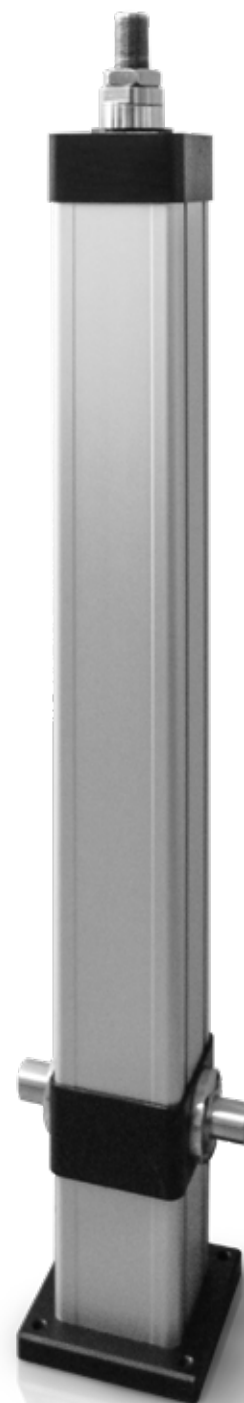

Features/Model Line	UM	Mech Force 50	Mech Force 63	Mech Force 80	Mech Force 100	Mech Force 125	Mech Force 150
Flange Size	mm	65 mm	75 mm	95 mm	115 mm	135 mm	165 mm
Diameter / Step Screw	mm	20/5-10-20	25/5-10-25	32/5-10-32	40/5-10-40	50/10	63/10-16-20
Dynamic load	kN	14,6-11-13,4	19,8-16-15,1	25,9-29,8-22,7	23,9-60,4-44,4	76,9	87,9-190-141,9
Axial force 2000km	kN	1,98-1,88-2,89	2,69-2,74-3,50	3,52-5,1-5,72	3,24-10,33-12,0	13,15	15-38-30,57
Maximum screw speed	rpm	4500	4500	4062	3250	2600	2063
Maximum axial speed	mm/s	1500	1875	2166	2167	433	688
Useful Ride* (Non standard available under request)	mm	50-500	50-600	50-800	50-800	50-1000	50-500

Mech Series

Automationware

Series: Value – Line – Force – Plus & Extreme

Mech Plus & Extreme Series

The **Mech Plus series** is suitable for the most extreme loads and adds very compact cylinder features.

In addition, the series has a graft for greasing the screw, in cases of heavy duty where an automatic lubrication is required. In the parallel version, it has a high resistance transmission belt and no backlash (*clearance 0*).

The profile has a reinforced structure and the pushing technology is built with ball screws with high dynamic loads combined with a structure of very compact snail, to always offer maximum performance.

There is a version called **Mech Extreme** with a dynamic load of over 750,000 Newton for high-load applications with extreme durability, based on an ISO 5 rectified screw system, designed to the **Automationware** specification.

This cylinder can be used for continuous loads of years to over 70000 Newton, ideal for extreme applications. (*Reinforced in steel*).

The whole series is ISO 15552 compatible, they can be motorized with Brushless or Stepper devices also coupled to reducers to keep the overall dimensions limited and offer a compact solution.

They can contain the **AwareVu** device to give a continuous feedback on the functioning in normal conditions, warning in advance about any unusual vibrations.



New

Features/Model Line	UM	Mech Plus 50	Mech Plus 63	Mech Plus 80	Mech Plus 100	Mech Plus 125	Mech Plus 160	Mech Plus Extreme
Flange Size	mm	65mm	75 mm	100mm	120mm	140mm	180mm	180mm
Diameter / Step Screw	mm	25P10	32P10	40P10	50P10	63P10	80P10 -20	50P40 ISO 5
Dynamic load	kN	19,9	33,8	78,6	97,8	109,7	121,9 - 213,7	414 - 752
Axial force 2000km	kN	3,4	5,78	13,44	16,72	18,76	20,84 - 46	92 - 184
Maximum screw speed	rpm	4500	4375	3500	2800	2222	1750	1500
Maximum axial speed	mm/s	750	729	583	467	370	292 - 583	1000
Useful Ride* (Non standard available under request)	mm	50-600	50-800	50-900	50-1100	50-1300	50-1500	50-1000

Mech Series

Automationware

Benefits and Selection Criteria

Characteristic	Mech Value (New)	Mech Line	Mech Force	Mech Plus
Size	16-25-32	25-32-50-63	50-63-80-100-150	50-63-80-100-150
Max Axial Force	1700 N	2400 N	190000 N	213000 N
Accuracy	0,02 +/-	0,02 +/-	0,01 +/-	0,01 +/-
Max Speed	0,5 m/s	1,5 m/s	2 m/s	0,75 m/s
Lubrication	manual	manual	manual (automatic on 150)	automatic (optional on 50)
Parallel drive	Y	Y	Y	Y
Gearbox	N	optional	optional	optional
Anti-rotation	Y	Y	Y	Y
Diagnostic Ind. 4.0	AwareVu™ (optional)	AwareVu™ (optional)	AwareVu™ (optional)	AwareVu™ (optional)
Motor	Stepper	Stepper & Brushless	Stepper & Brushless	Brushless

Applications

Mech Value Series: A revolution on small-sized cylinders

Ideal cylinders for small-scale applications, to replace pneumatic systems and achieve precise and rapid speed modulation, with intermediate positions and adjustable acceleration.

Available with the new Stepper motor, which allows for cost saving and size reduction, **always with a view to precise positioning control.**

Mech Line Series: Ideal for medium-scale industrial applications

Ideal electric cylinders for industrial applications with medium applicable strength, an excellent alternative to pneumatic or hydraulic cylinders with remarkably low operating costs.

They are designed for long life without maintenance, and include a set of accessories suitable for any configuration.

Mech Force & Mech Plus Series: Ind. 4.0 Resistance and Technology, uncompromising

Excellent cylinders for the most extreme applications, where high drive and/or long operation are required.

The dynamic loads of the sphere recirculation screws are among the highest on the market, ensuring top quality as well as cutting-edge drive performance levels.

The Plus Series adds Ind. 4.0 technology and compactness as standard.

(Automationware AwareVu patent which prevents three-dimensional vibrations using an electronic system in the base of the cylinder, which can also be controlled via Wi-Fi to check any malfunctioning in the system.)

Performance tables for the **Mech Plus** and **Mech Force** series
(Duration as a function of the load)

Mech Plus - Force Vs. Life expressed in km (based at 500 rpm)

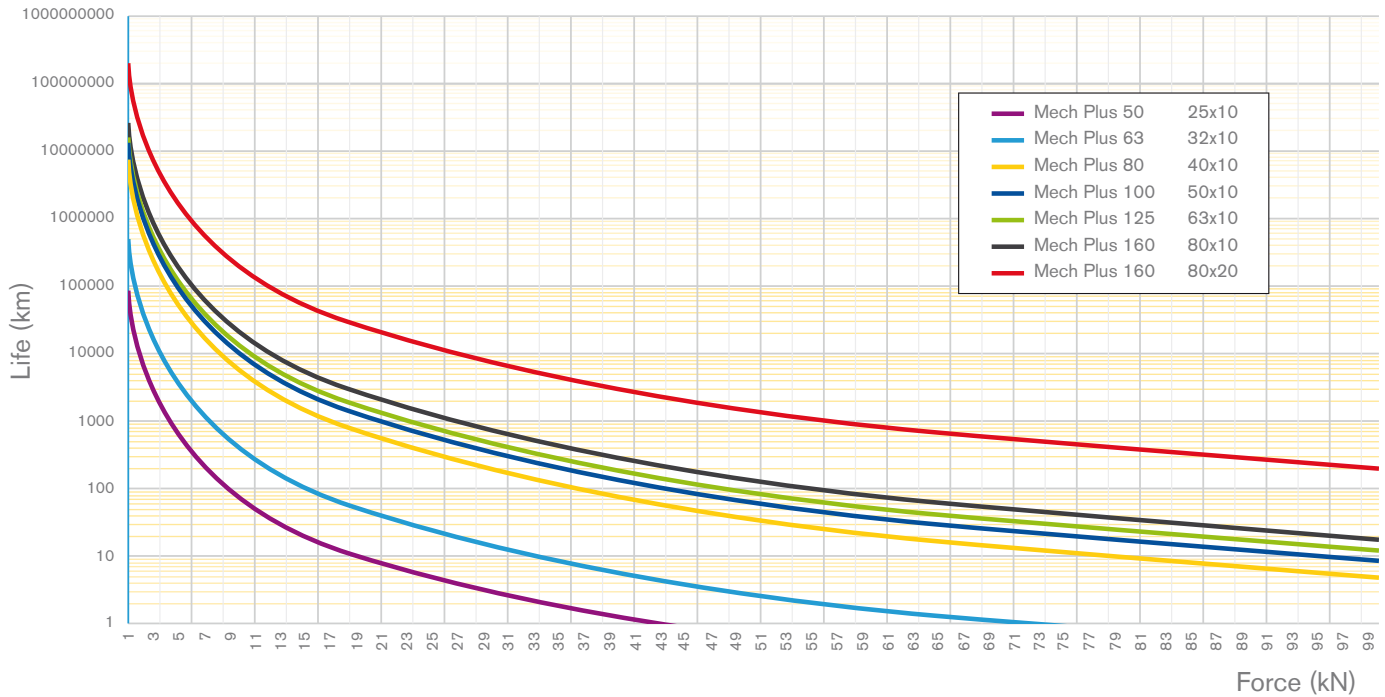

Mech Force - Force Vs. Life expressed in km (based at 500 rpm)

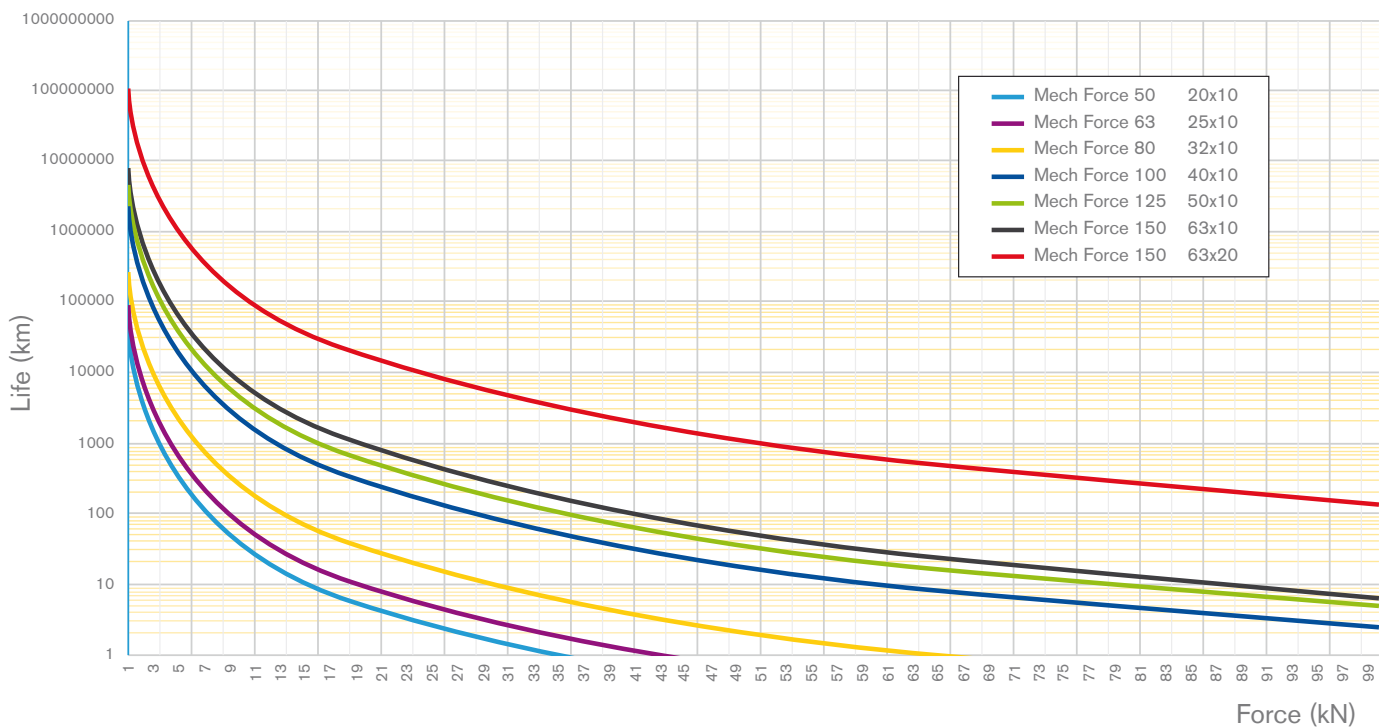

The tables in figure show the operational performance levels in km as a function of the loads applied in kNewton (at a speed of 500 rpm).

The tables are merely indicative: we always recommend sizing depending on the work cycle, speed and load applied.

Applications

Automotive and heavy load moving

The automotive industry sector often requires the use of hydraulic cylinders for the production chain and for the components-assembly phase (*Use of the cylinders as press.*)

The easy installation and the easy programming, makes them very useful to avoid complex pneumatic or hydraulic installations.

Diagnostic and Healthcare

The electric cylinder can be very useful for micrometric movements on scanning devices and TAC. The system also maintains the position, even without power supply. In absence of the hydraulic, it is the ideal solution to simplify the design of the compact and transportable medical diagnostic systems.

It allows the accurate positioning of persons and objects for the electronically programmable diagnostics. For the pharmacological production cycles, the electric cylinders prevent each contamination, allow the product packaging in aseptic rooms with precision and minimal maintenance.

Automationware provides also linear axes, combinable with other Pick & Place solutions for the packaging of pharmacological products for automated diagnostic.



Packaging and/or material motion

Very useful for packaging systems, ideal solution for industrial applications, such as the logistics, if the material movement needs high forces, modulate movements, also with high speed.

Aerospace & Defence

Many defence applications need industrial actuators to moderate the investment, maintaining an excellent level of quality and easy use in normal application situations.

Our cylinders offer a very good applicability for different configurations, such as navigation simulators (*also militar*). Very useful also for the logistic applications, if the IP65 protection can be appropriate.

Factory automation

Essential in modern palletising systems, excellent in industrial production chains to find a rapid solution to eventual line problems. Very useful for the warehouses, as extending and upgrading of existing facilities.

Energy

Widely used for the flow control of the hydroelectric turbines, for easy installation and regulability. Widely used also for wind-power applications, for the variation of the incidence angle of the blades.

Very useful also for fuel extraction or fuel production installations, thanks to its easy maintenance and management, also by remote control.

Machine tools

Used as substitutes for hydraulic systems of machines for metal sheets bending.

The easy use and the simplification of systems make them very popular in the applications that need the “press” type operation. They can also be used in very vertical applications, such as tyre-inserting machines, simplifying the hydraulic inserting systems. Machine tools for the production of springs or for the mechanical component insertion, such as bearings, bushings, ringnuts, reducing the complexity of the systems, modulating the pressure with programmed motion.



Mech Plus

Automationware

Designed to offer
the best combination of force performance
with a compact and solid form factor

Gearbox

With very high efficiency using
a best performance helicoidal
planetary system for long life and
low noise level (Backlash ≤ 5)

Permanent Magnetic

system included on the roller screw
ball system for accurate positioning
optimization

Magnetic detectors

Inserted on chassis (no external wires)

Head bearing

with self-lubrication for lower degradation

Dust scraper

Seal to avoid
contamination from
external and selected
for severe temperature
variation (degree of
protection IP 65) –
Double protection for
hostile situation

GGB bearings

to prevent vibrations in
high speed

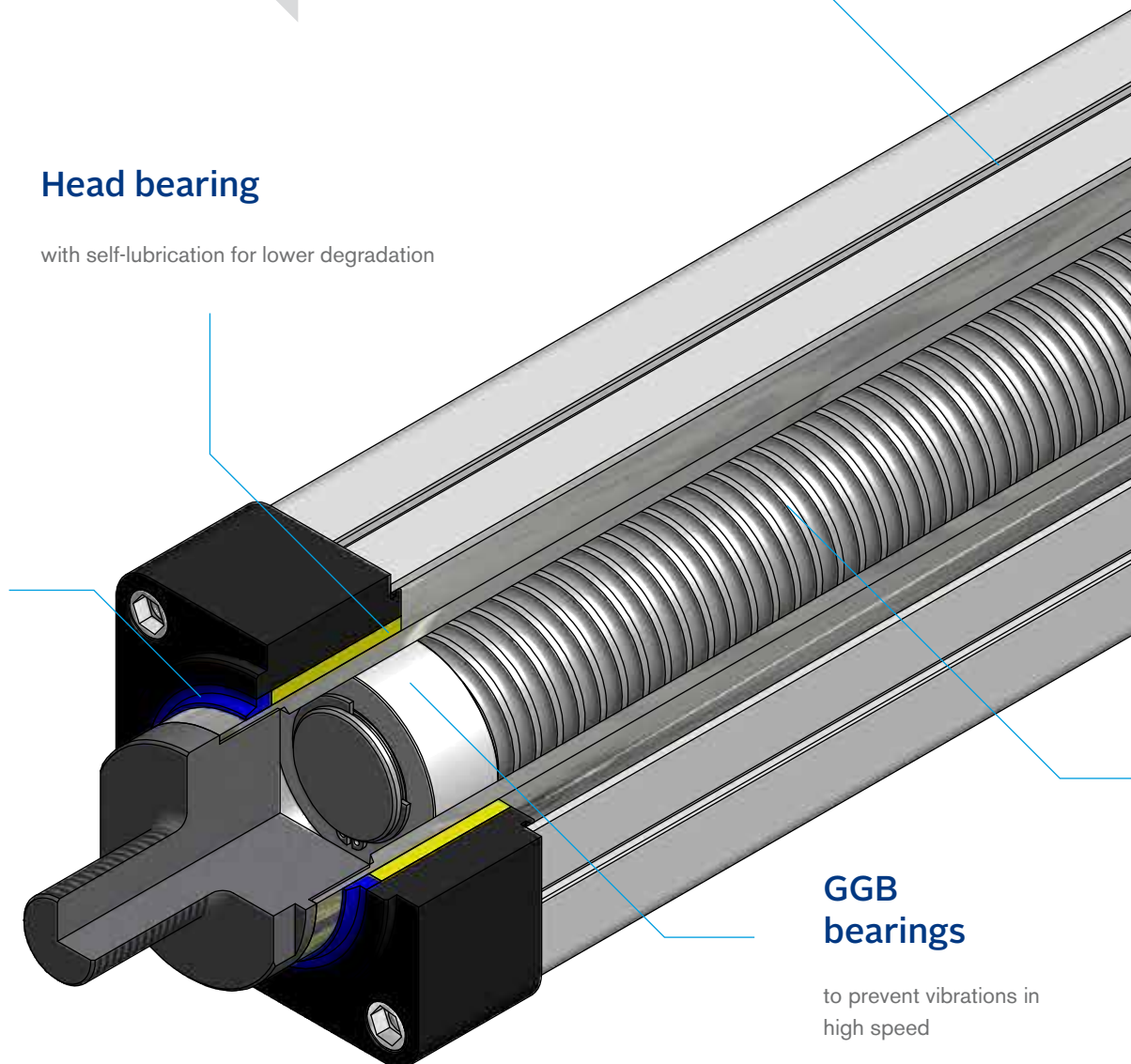

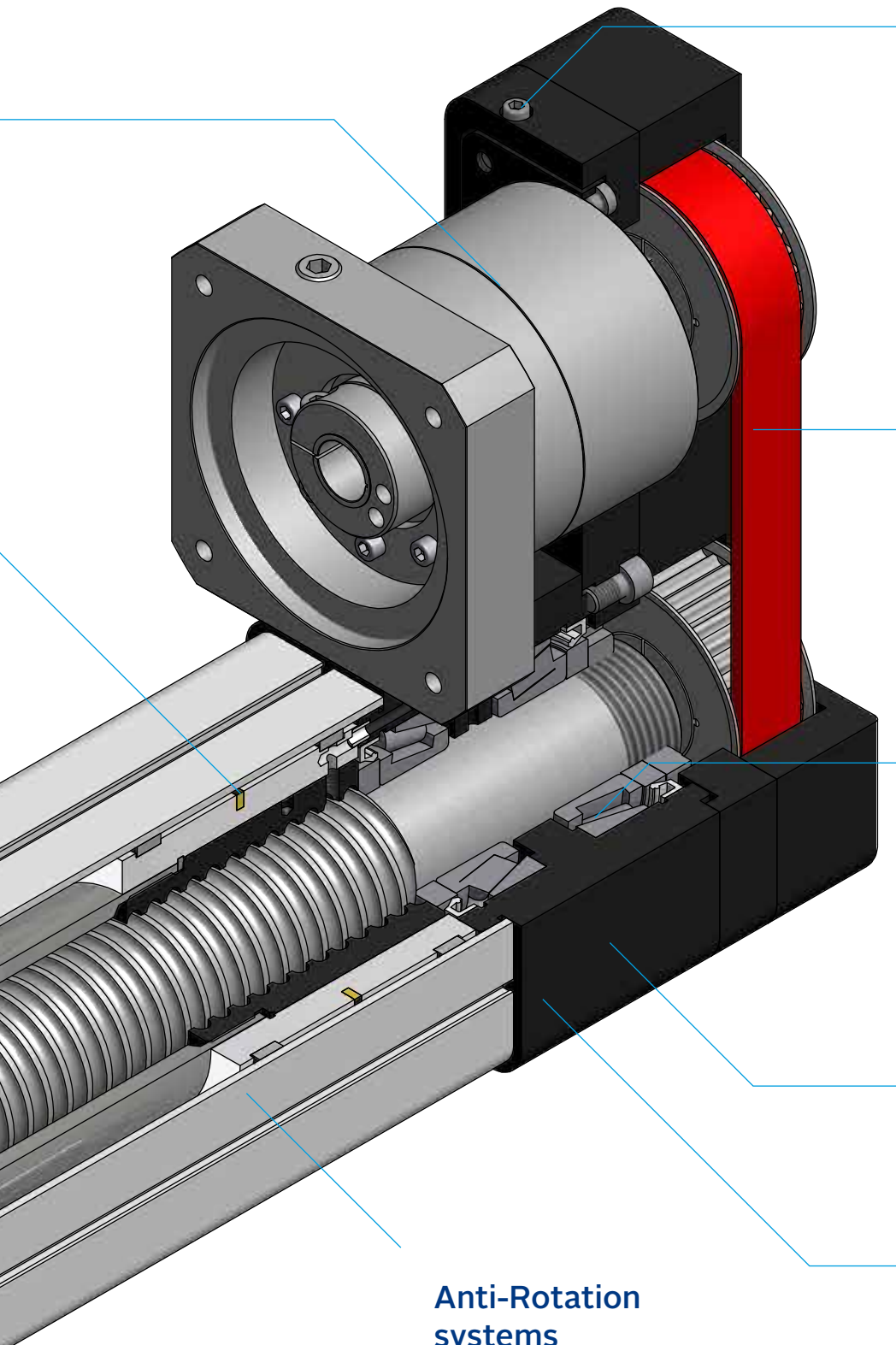

Micrometric Belt tension system

With factory pre-setup for best efficiency and accuracy

High performance Kevlar

belt for high durability stiffness

Lubrication system

Tapered roller bearings, with high capacity torque and pin for centralized lubrication system

Lateral pins

Optional lateral pins for heavy loads operations

Anti-Rotation systems

Cylinder with **anti-rotation** systems included



AwareVu™

Vibration and Temperature Control for Ind. 4.0 Diagnostics

Roller balls screw ISO 7

(ISO 5 optional), for long life span and heavy load

Mech Series

Automationware

Drives and Diagnostics Ind. 4.0

Motors and Drives	I/O	CANopen	Ethercat	Profinet	Mech Value (New)	Mech Line	Mech Force	Mech Plus
Drive AW EZI	X	na	optional	na	Stepper (Nema xx)	Stepper (Nema xx)	na	na
Drive AW ECMA	X	X	X	na	na	Brushless	Brushless	na
Drive AW ServoOne	X	X	X	X	na	na	Brushless High Torque	Brushless High Torque
Encoder	Incremental				Sensorless / Optional	Required / Sensorless	Required	Required
Easy Software	Move Modelling				Option	Option	Option	Option
AwareVu	3D vibration Diagnostic Ind. 4.0				Optional	Optional	Optional	Included

Market Ahead solutions to achieve Ind. 4.0 movement, control and diagnostics on your mechatronic components

All cylinders in the Mech series can be fitted with **Stepper** or **Brushless** motors.

The **Stepper** power system includes the possibility of encoder or **sensorless** control, in order to make the cylinder more compact and economical, always guaranteeing precise positioning thanks to a technology which detects position based on electric operation parameters.

With **Brushless** motors very high axial speeds can be achieved, always with the utmost precision, thanks to a wide range of available encoders.

It is based on a full-closed loop control system, with **auto notch filter** which prevents vibrations also at high productivity levels to reduce noise during operation.

The 17-bit encoder guarantees high positioning precision, allowing for a 0.01 mm precision.

If the cylinders need to be used in coordination on several axes (for example in *TRIPOD- Simulator systems*), as an option, we offer a **four-axis** driver with **TRIO software**, in order to allow for advanced motion interpolation.

This axial system control may include our EZI – ECMA -ServoOne drivers, which can all be integrated in a single chassis.

The integrated **E-Cam** connection allows for easy synchronization of motion and positioning with cameras.

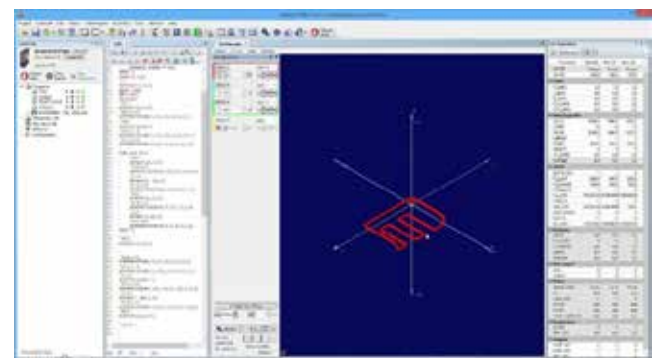

For basic applications, **Automationware** has a control software system called **Easy** which can be installed on a standard PC or Tablet and connected via a USB or Serial interface to the control electronics.

The following figure illustrates the main menu of the **Easy** software.

It is possible to set as many as 64 positions, each of them characterized by adjustable speed and acceleration.

Positioning data can be defined in an absolute or relative way with regard to the current location.

The command selection for the various positions (*in succession or random*) makes it possible to simulate automated operation of the actuator.

If this command is entered, the actuator moves to the required position and a graphical indication is given of the position reached.



Sistema AwareVu™, for Ind. 4.0 diagnostics



Electronic control installed on the base of the electric cylinder (as standard on Mech Plus)

AW has developed a new diagnostic system called **AwareVu™** (Patent Pending).

It allows for actuator monitoring through temperature and vibration checks, in order to identify any faults during operation phases also due to factors external to the cylinder.

The system is designed to trigger a local warning (*Light Alarm*), as well as being collected via WIFI or via USB to the network, which makes it possible to save production parameter data, in the central computer or in cloud.

The system also includes Mobile Phone or Tablet applications, in order to warn maintenance operators about possible malfunctioning, with the possibility of displaying data, parameters or alarms on screen.

The system stores and processes signals from vibration and temperature sensors; this produces a frequency profile diagram (*Fourier series*), which allows the client to set threshold values, to be warned in the event of unusual vibrations or excessive temperature variations (*also on an individual system component*).



Mech Value

Automationware

Accessories

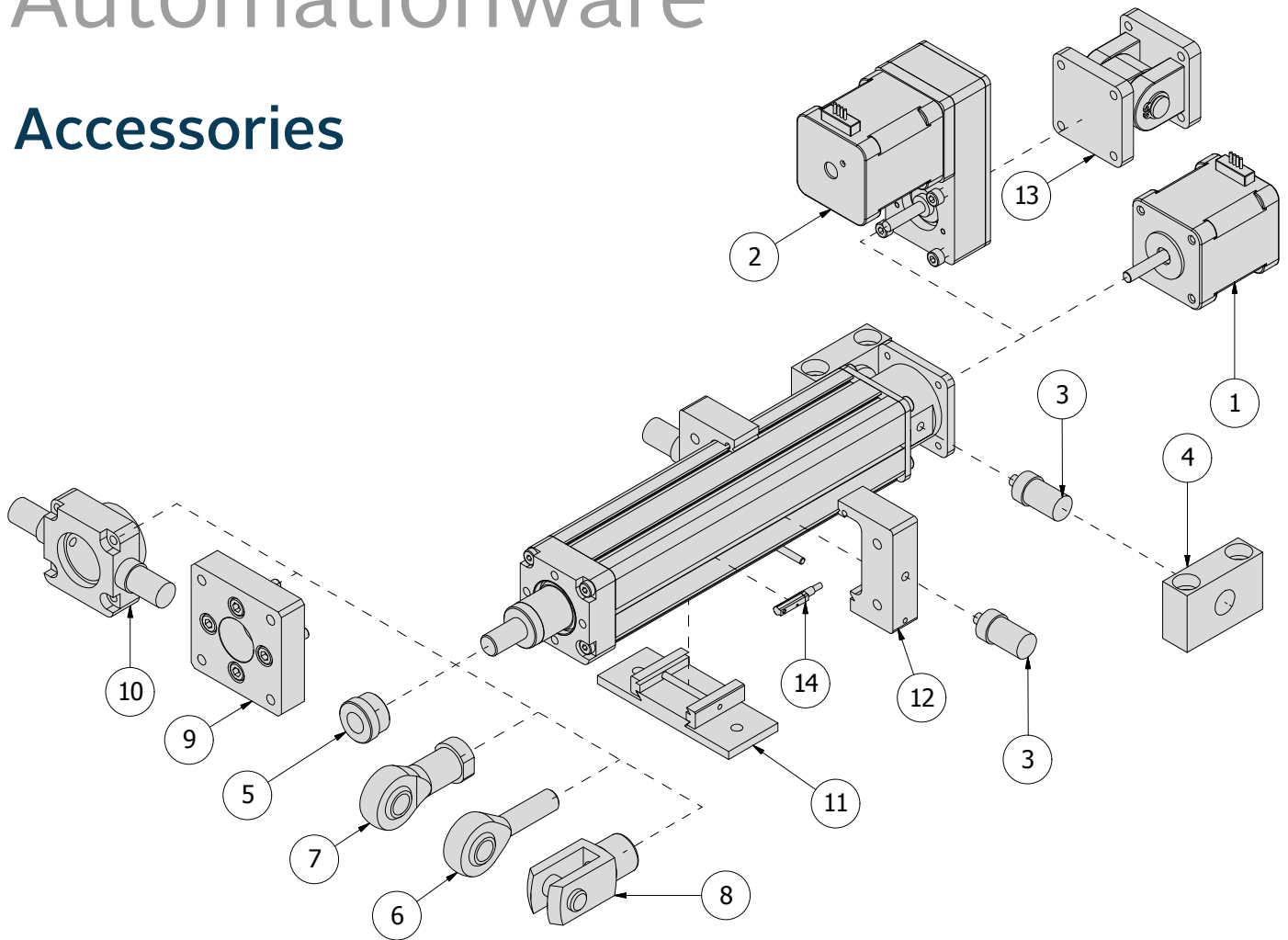

MECH VALUE ACCESSORIES

POSITION	DESCRIPTIONS
1	Direct drive Kit
2	Parallel Drive Kit
3	Lateral PIN kit
4	Adjustable intermediate zipper kit
5	Kit pins on poster head
6	Support kit for pins
7	Fixing kit on top
8	Front spherical joint
9	Threaded anterior spherical joint
10	Front fork joint
11	Pierced nipple
12	Backward joint swinging kit
13	Front interface plate kit
14	effect hall sensor

Dimensions and Components

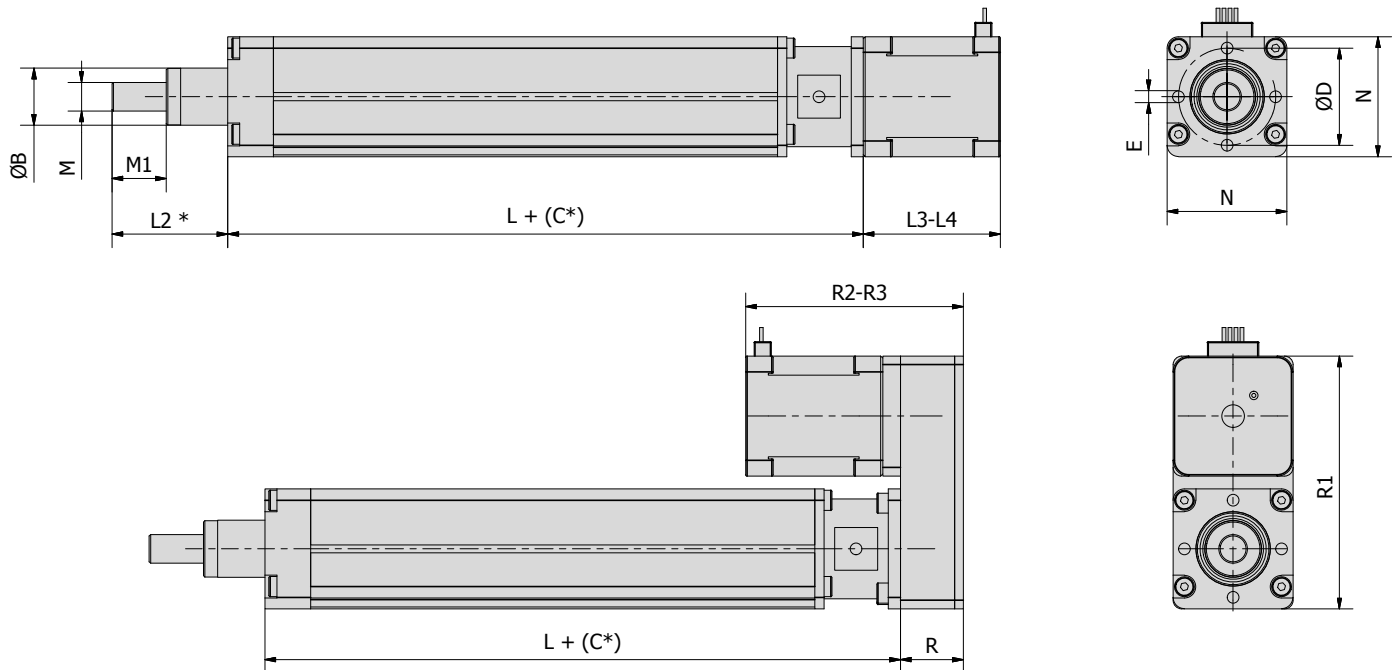

DIMENSION: Base Version, Direct drive Parallel Drive

Actuator Size	UM	Mech Value 16	Mech Value 25	Mech Value 32
Lead screw	mm	8x3-8	10x3-10	12x5-10
ØB	mm	16	18	20
ØD	mm	25	28	34
E	mm	M4x8	M3x8	M6x12
L	mm	88,5	105,5	122,5
L2*	mm	28	34	40,5
L3	mm	45	38	48
L4	mm	50	53	60
M	mm	M6	M8	M10x1,25
M1	mm	12	16	19
N	mm	30	32	42
R	mm	17	17	22
R1	mm	60,5	75,5	88,5
R2	mm	69,7	62,7	76,2
R3	mm	74,7	77,7	88,2

L2*= QUOTA TO BE MODIFIED IN CASE OF INTERFACE FLANGE ADDITION:

Mech 16 = 12 mm Mech 25 = 44 mm Mech 32 = 54,5 mm

L3 = short motor R2 = short motor

L4 = long motor R3 = long motor

Mech Line/Force Automationware

Accessories

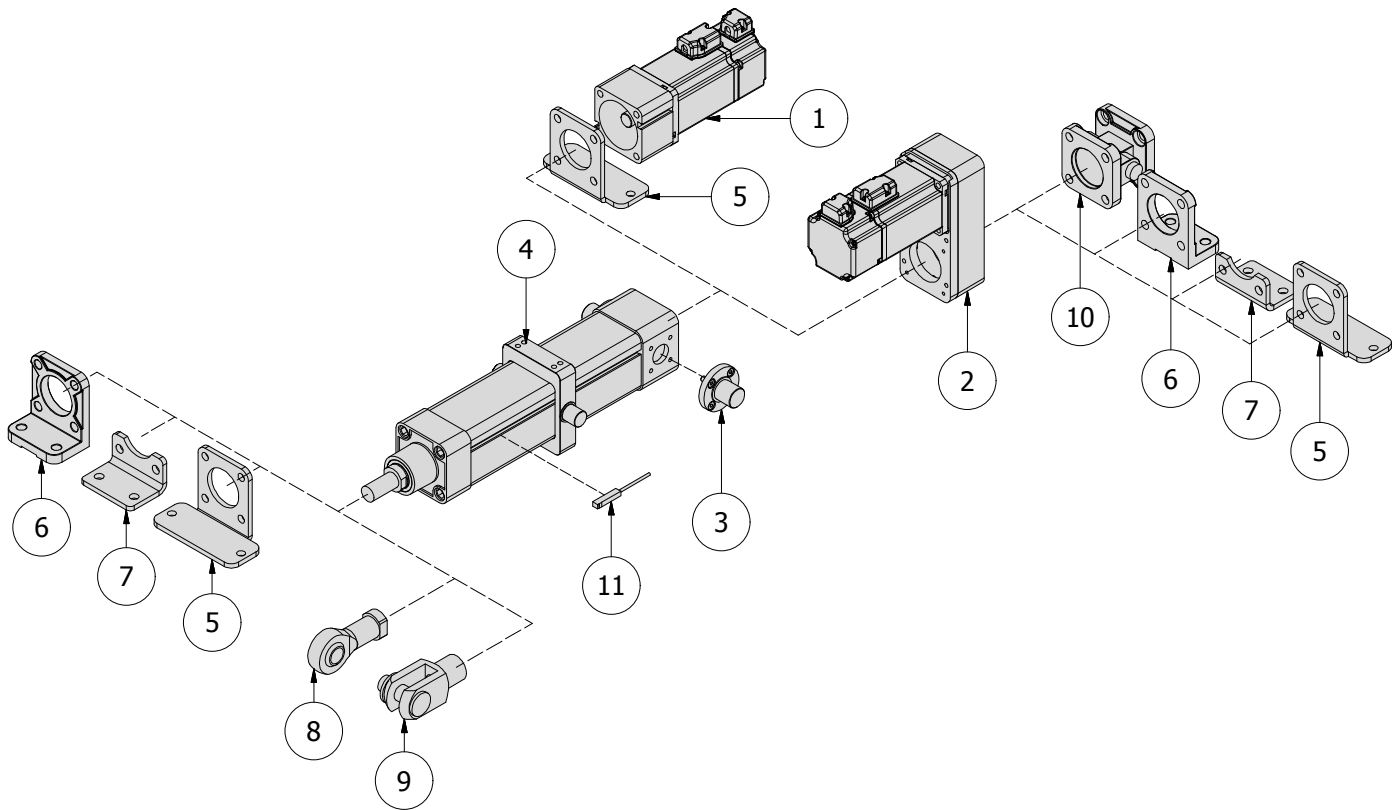

MECH LINE/FORCE ACCESSORIES

POSITION	DESCRIPTIONS
1	Direct drive Kit
2	Parallel Drive Kit
3	Lateral PIN kit
4	Lateral flange support for lateral Kit
5	wider Lateral flange support Kit
6	flange support Kit
7	Lower flange support Kit
8	Clevis rod end
9	Fork rod end
10	Backward joint swinging kit
11	effect hall sensor
	Available Gearbox 3-4-5-7-10-16-20

Dimensions and Components

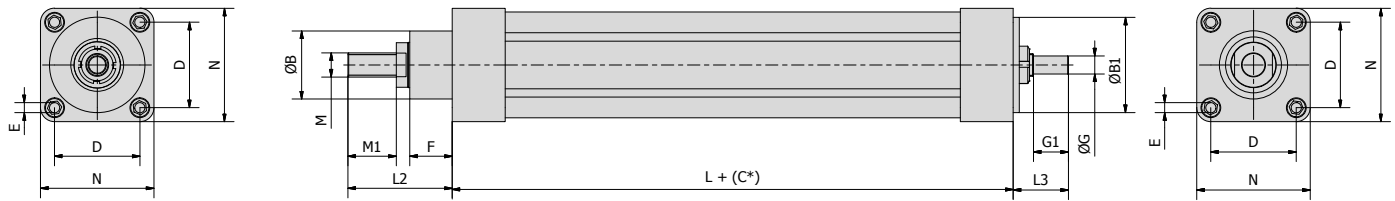

DIMENSION: Base Version, Direct drive Parallel Drive

Actuator Size	UM	Mech Line 25	Mech Line 32	Mech Line 50	Mech Line 63
Lead screw	mm	12x5-10	12x5-10	16x5-10-16	20x5-10-20
ØB	mm	-	30	40	45
ØB1	mm	22	32	50	63
D	mm	Ø26	32,5	46,5	56,5
E	mm	N°4 M3x5	N°4 M6x18	N°4 M8x15	N°4 M8x15
ØG	mm	-	20	28	28
L	mm	Ø6 h8	Ø8 h8	Ø10 h8	Ø12 h8
L2	mm	12,5	16,5	16	23,1
L3	mm	97,3	129	134	171
M	mm	24	48	41	41
M1	mm	20	25,5	27,5	36,5
N	mm	M8	M10x1,25	M16x1,5	M16x1,5
M1	mm	20	20	32	32
N	mm	32	47	65	75

*C = Corsa

DIMENSION: Base Version, Direct drive Parallel Drive

Actuator Size	UM	Mech Force 50	Mech Force 63	Mech Force 80	Mech Force 100	Mech Force 125	Mech Force 150
Lead screw	mm	20x5-10-20	25x5-10-25	32x5-10-20-32	40x5-10-20-40	50x5-10-40	63x10-16-20
ØB	mm	40	45	55	70	90	90
ØB1	mm	50	63	80	100	125	150
D	mm	46,5	56,5	72	89	Ø130	Ø130
E	mm	N°4 M8x18	N°4 M8x18	N°4 M10x20	N°4 M10x20	N°8 M10x25	N°8 M16x30
ØG	mm	3	3	3	3	3	3
L	mm	Ø12 h8	Ø14 h8	Ø17 h8	Ø24 h8	Ø32 h8	Ø32 h8
L2	mm	24,5	27	31	40,5	48	50
L3	mm	173	182	228	285	300	438
M	mm	45	55	60	70	105	95
M1	mm	34	36,4	40	52,6	61	64
N	mm	M16x1,5	M20x1,5	M20x1,5	M27x2	M30x2	M36x3
M1	mm	32	40	40	50	60	60
N	mm	65	75	95	115	135	165

*C = Corsa

Mech Plus

Automationware

Accessories

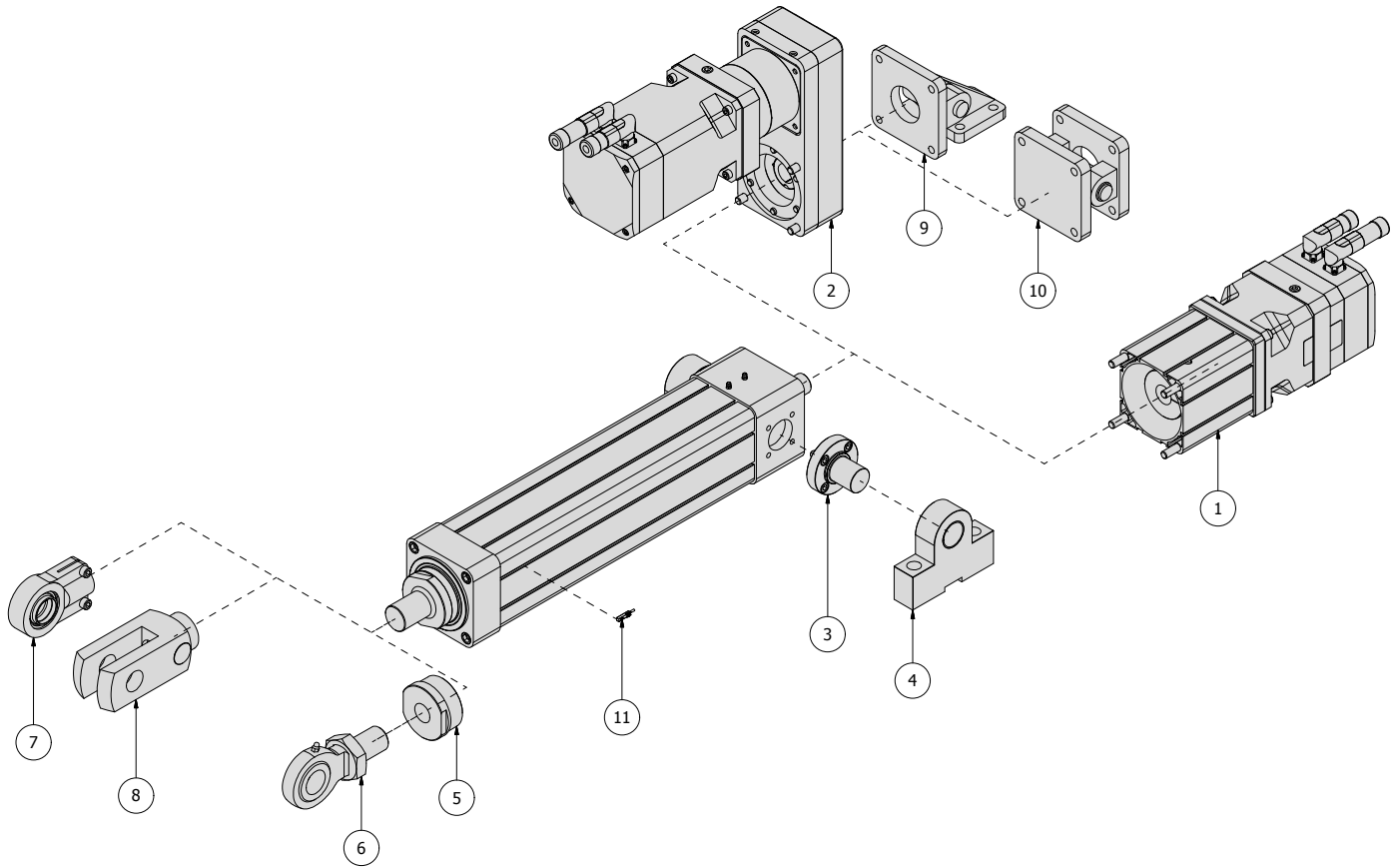

MECH PLUS ACCESSORIES

POSITION	DESCRIPTIONS
1	Direct drive Kit
2	Parallel Drive Kit
3	Lateral PIN kit
4	Lateral flange support for lateral Kit
5	Female threaded
6	Spherical rod end
7	Clevis rod end
8	Fork rod end
9	90° Backward joint swinging kit
10	Backward joint swinging kit
11	effect hall sensor
	Available Gearbox 3-4-5-7-10-16-20

Dimensions and Components

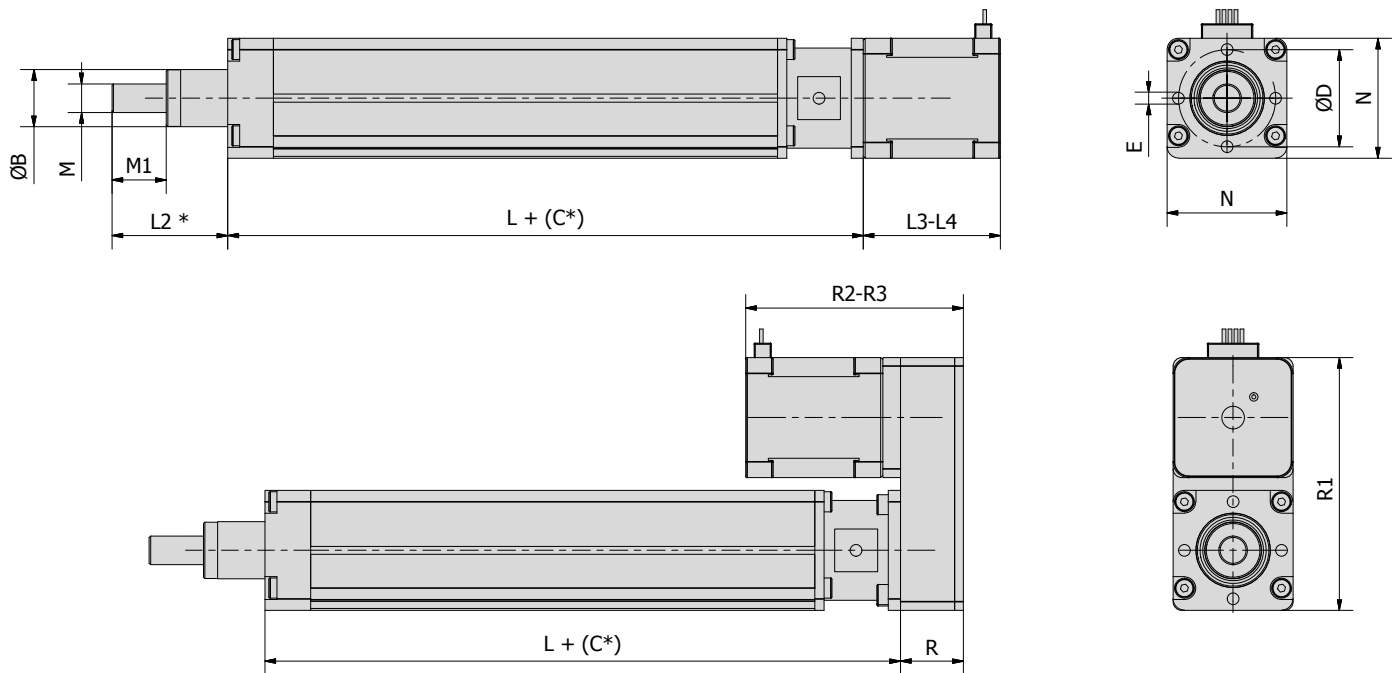

DIMENSION: Base Version, Direct drive Parallel Drive

Actuator Size	UM	PLUS 050	PLUS 063	PLUS 080	PLUS 100	PLUS 125	PLUS 160	
Lead screw	mm	P10	P10	P10	P10	P10	P10	P20
A1		17	20	23	28,5	30,5	45	45
A2		17	20	23	28,5	30,5	45	45
A3		27	30	41	55,5	50,5	60	60
A4		27	30	39	47,5	50,5	60	60
A5		24	34	40	50	70	80	80
ØB		50 g6	70 g6	80 g6	100 g6	120 g6	160g6	160g6
ØB1		50 g6	63 g6	80 g6	100 g6	125 g6	160g6	160g6
D		46,5	56,5	72	89	110	140	140
ØD		45	58	71	88,8	112	140	140
E1		M8x18	M8x18	M10x20	M10x20	M12x20	M16x30	M16x30
E2		M8x10	M8x10	M12x12	M16x20	M16x20	M20x30	M20x30
E3		N°6 M4x12	N°8 M4x12	N°8 M4x12	N°8 M5x12	N°4 M10x20	N°8 M10x20	N°8 M10x20
F		3	3	5	6	6	10	10
F1		3	6	6	6	6	13	13
ØG		14 h7	16 h7	22 h7	25 h7	32 h7	35 h7	35 h7
G1		22	25	28	38	45	46	46
H		5	6	8	10	10	10	10
H1		16	20	20	36	40	40	40
ØI		40	55	65	80	90	120	120
ØI1		28	38	44	56	75	85	85
L		132	147	178	216	219,5	270	325
L1		176	197	240	292	300,5	375	430
L2		56	64	70	76	90	118	118
L3		36,5	46,5	49	63	69	80	80
M		M20x1,5	M20x1,5	M27x2	M27x2	M33x2	M42X2	M42X2
M1		35	40	45	45	60	80	80
N		65	75	100	120	140	180	180
P		157	204,5	243	283,7	302	356	363,5
P1		189	225,5	231	311,5	239,5	390,5	398
R		43	58	58	70	78	107	107
R1		65	75	100	120	139	180	180
R2		150	190	227	305	320	415	415
R3		110	152	177	211	212	264	264
R4		142	168	165	238,5	328,5	298,5	298,5

*C= Corsa

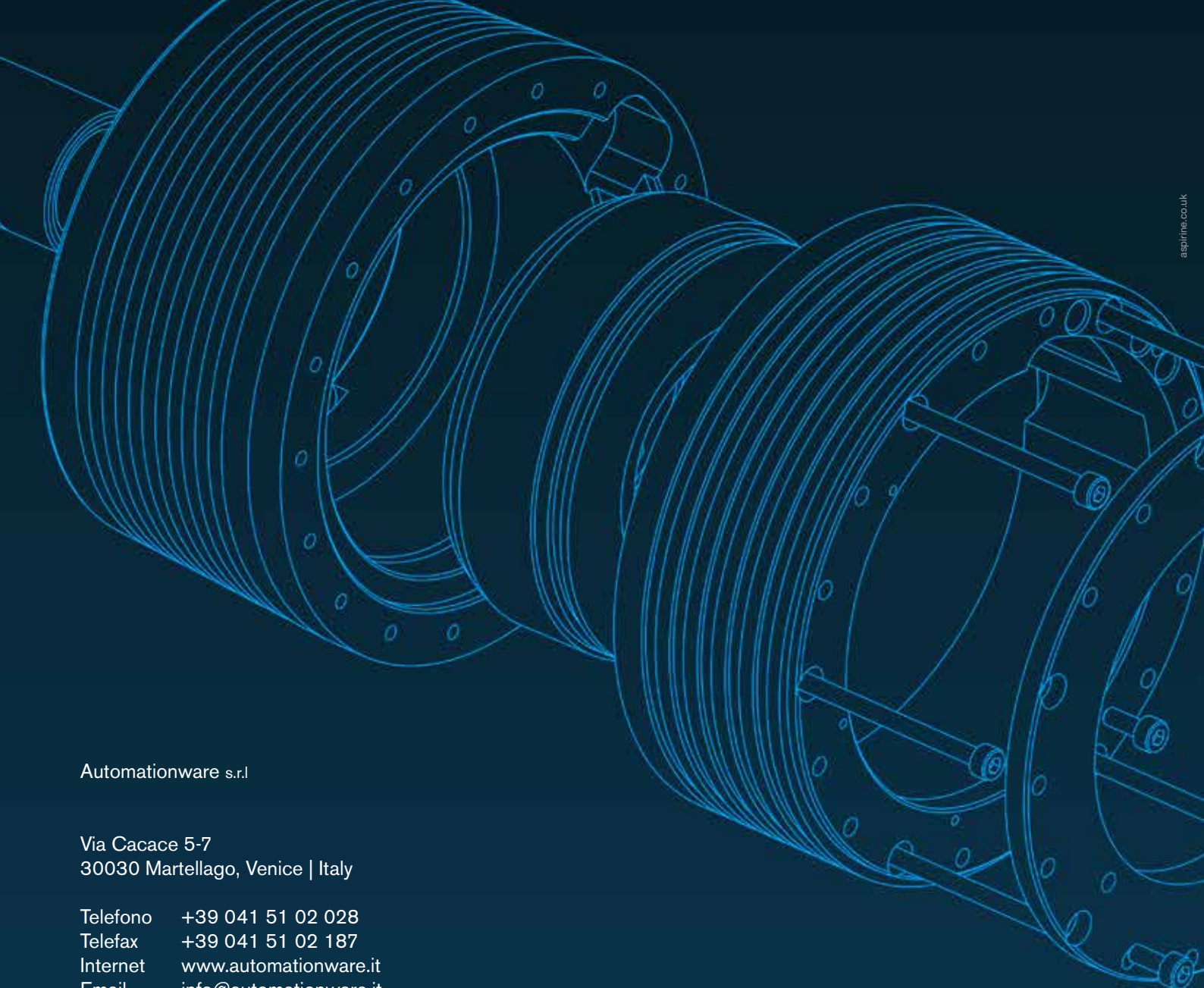

Automationware s.r.l

Via Cacace 5-7
30030 Martellago, Venice | Italy

Telefono +39 041 51 02 028
Telefax +39 041 51 02 187
Internet www.automationware.it
Email info@automationware.it

Join the community



© 2019 by AutomationWare – all rights reserved. This brochure contains indicative parameters. AutomationWare reserves the right to modify any specification at any time. For a more detailed consultation we recommend the use of the technical datasheet and/or to visit our website www.automationware.it.

All the material contained in this website is the property of AutomationWare and/or of the quoted companies; to it the Italian and European laws in matter of Copywrite are enforceable; any text taken from other sources is also protected by the Copywrite and Property rights of the respective Trademarks. All information and contents (*texts, graphics and images*) reported in this catalogue are, to the best of our knowledge, public property; if material subject to Copywrite or in infringement of the law has unintentionally been published, please inform us and we'll immediately remove it. All the trademarks shown belong to their legal owners; third party trademarks, product names, commercial names, corporate names, and companies quoted could be proprietary trademarks of their legal owners or registered trademarks of other companies and have been use for explanatory purposes only and for the benefit of the owners, without any intention of infringing the current Copywrite laws.